

PROJECT PLAN INDEX

| | |
|---------------------|----|
| DISCLAIMER | 1 |
| OUTSIDE POST LAYOUT | 2 |
| INSIDE POST LAYOUT | 3 |
| FLOORJOIST PLAN | 4 |
| DECKING PLAN | 5 |
| CEILING JOIST PLAN | 6 |
| ROOF FRAMING PLAN | 7 |
| FRONT ELEVATION | 8 |
| REAR ELEVATION | 9 |
| RIGHT ELEVATIONS | 10 |
| LEFT ELEVATION | 11 |
| WALL SECTION | 12 |
| ROOFBEAM TIE IN | 13 |
| POST CONNECTION | 14 |
| POST DETAIL | 15 |
| ROOF FRAMING DETAIL | 16 |
| ROOFING DETAIL | 17 |

You do not have resell rights or giveaway rights to this plan. Only customers that have purchased this material are authorized to view it. If you think you may have an illegally distributed copy of this plan, please contact us. Please email service@gardengazeboplans.com to report illegal distribution. Over time we have updated and revised this plan in an attempt to keep it current and as accurate as possible. Please note that you are responsible for any actions you take as a result of reading the ideas in this plan however. All rights reserved. Unauthorized distribution, resell, or copying of this material is unlawful. No portion of this plan may be copied or resold without written permission. COASTAL HOME DESIGNS LLC reserves the right to use the full force of the law in the protection of its intellectual property including the contents, ideas, and expressions contained herein. Be aware that we actively cooperate in quickly closing the account of copyright violators and assisting in legal pursuit of violators.

The publisher disclaims any personal liability, loss, or risk incurred as a result of any information or any advice contained herein, either directly or indirectly. The Publisher does not intend to render any legal, accounting, or other professional advice in the document contained herein. The author makes no representation or warranties of any kind with regard to the completeness or accuracy of the contents of this plan.

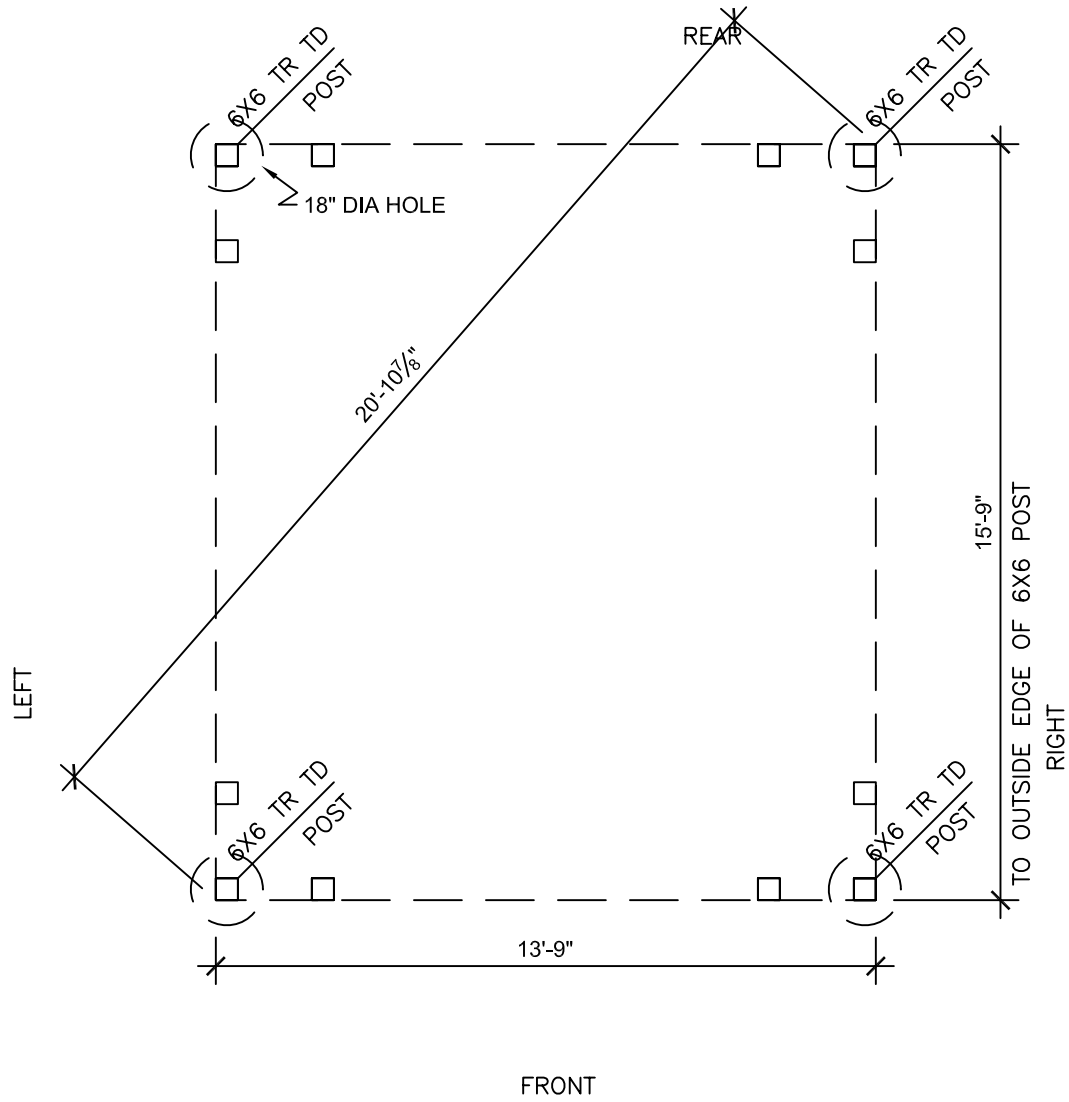

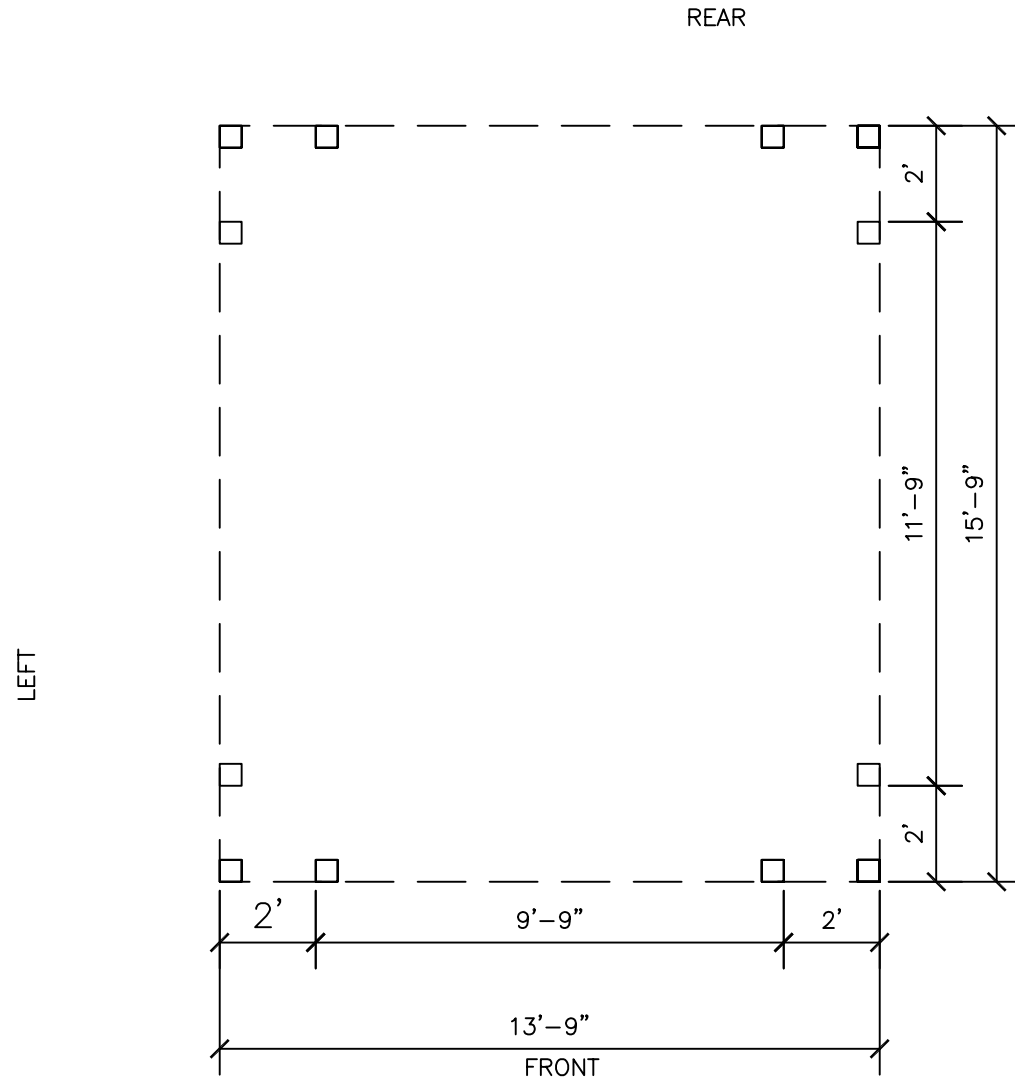

REAR

LEFT

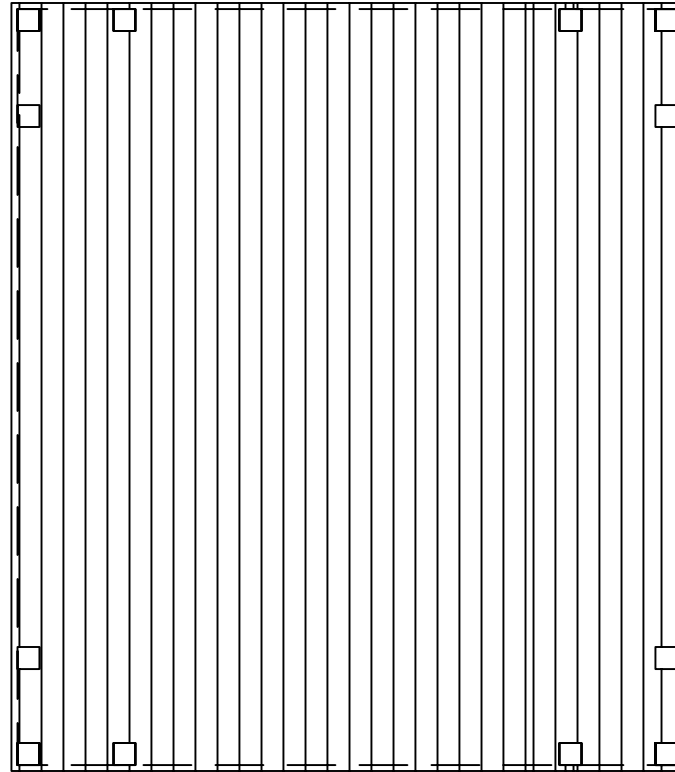

2X6 TR TD DECKING
START INSTALLING DECKING
ON THIS SIDE.

FRONT

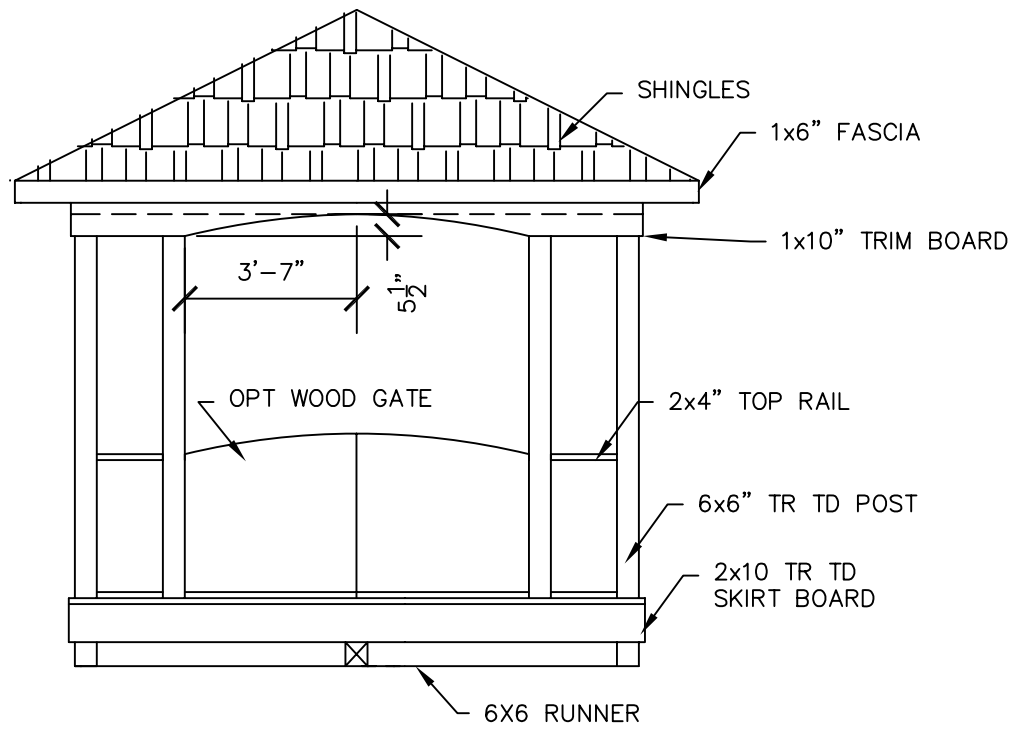

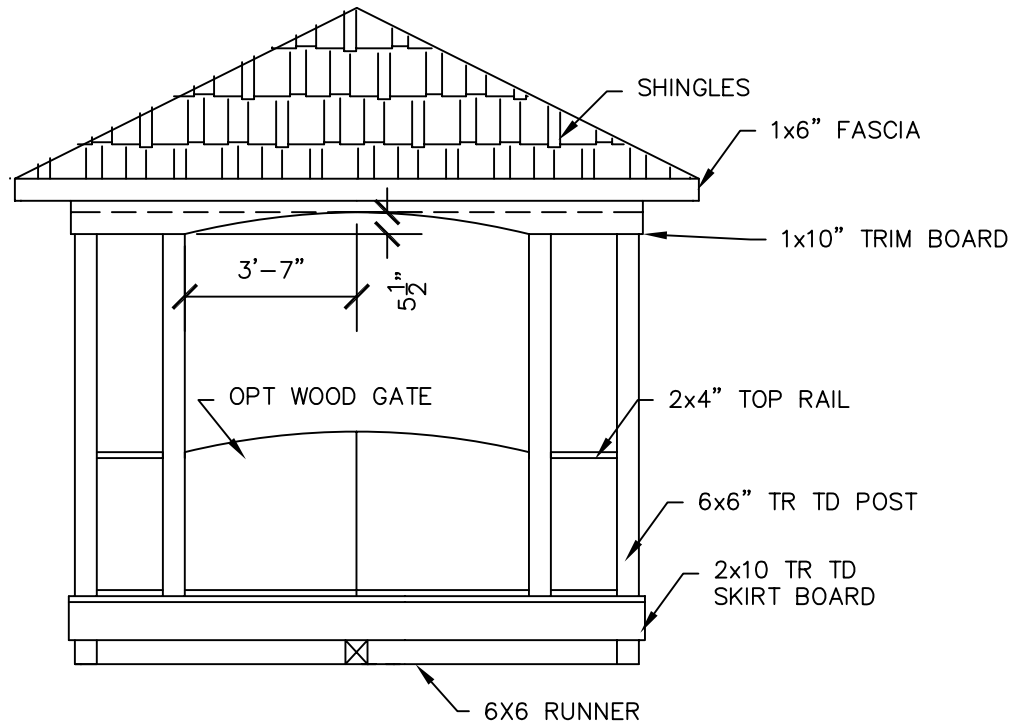

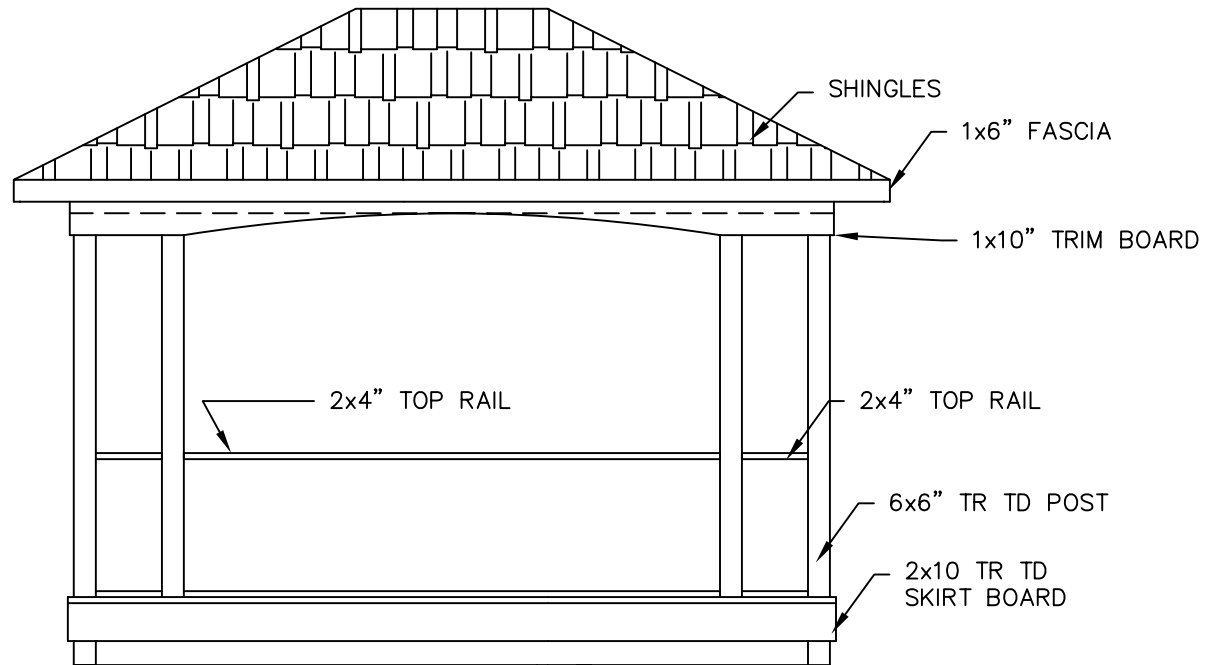

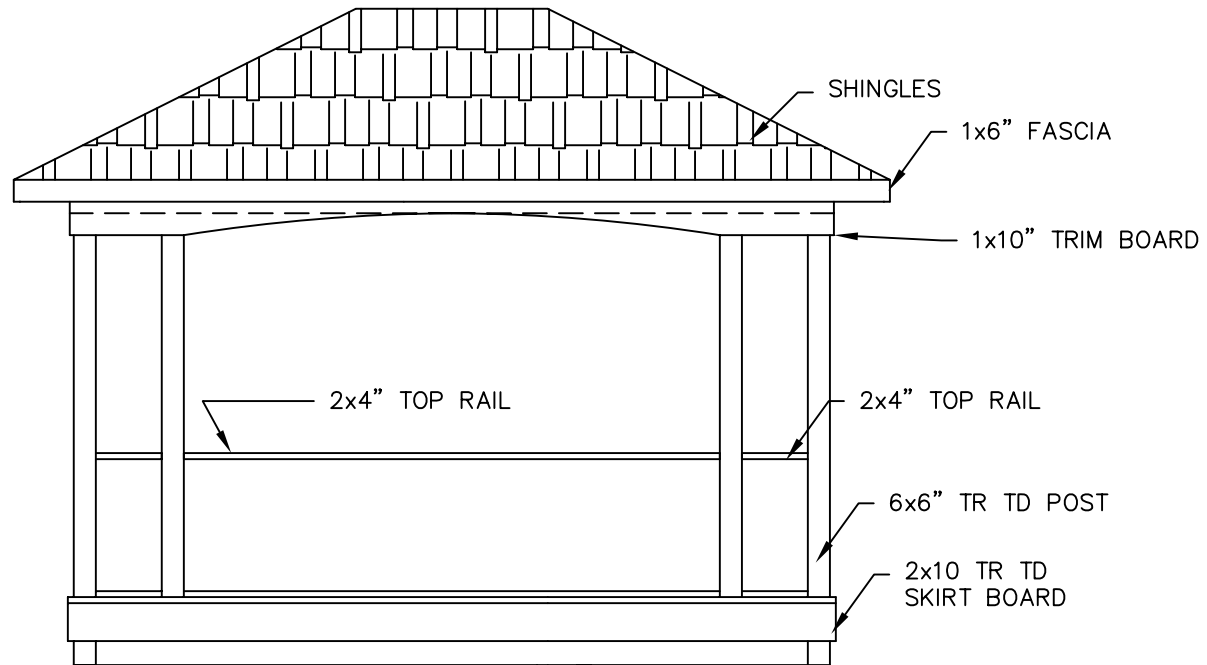

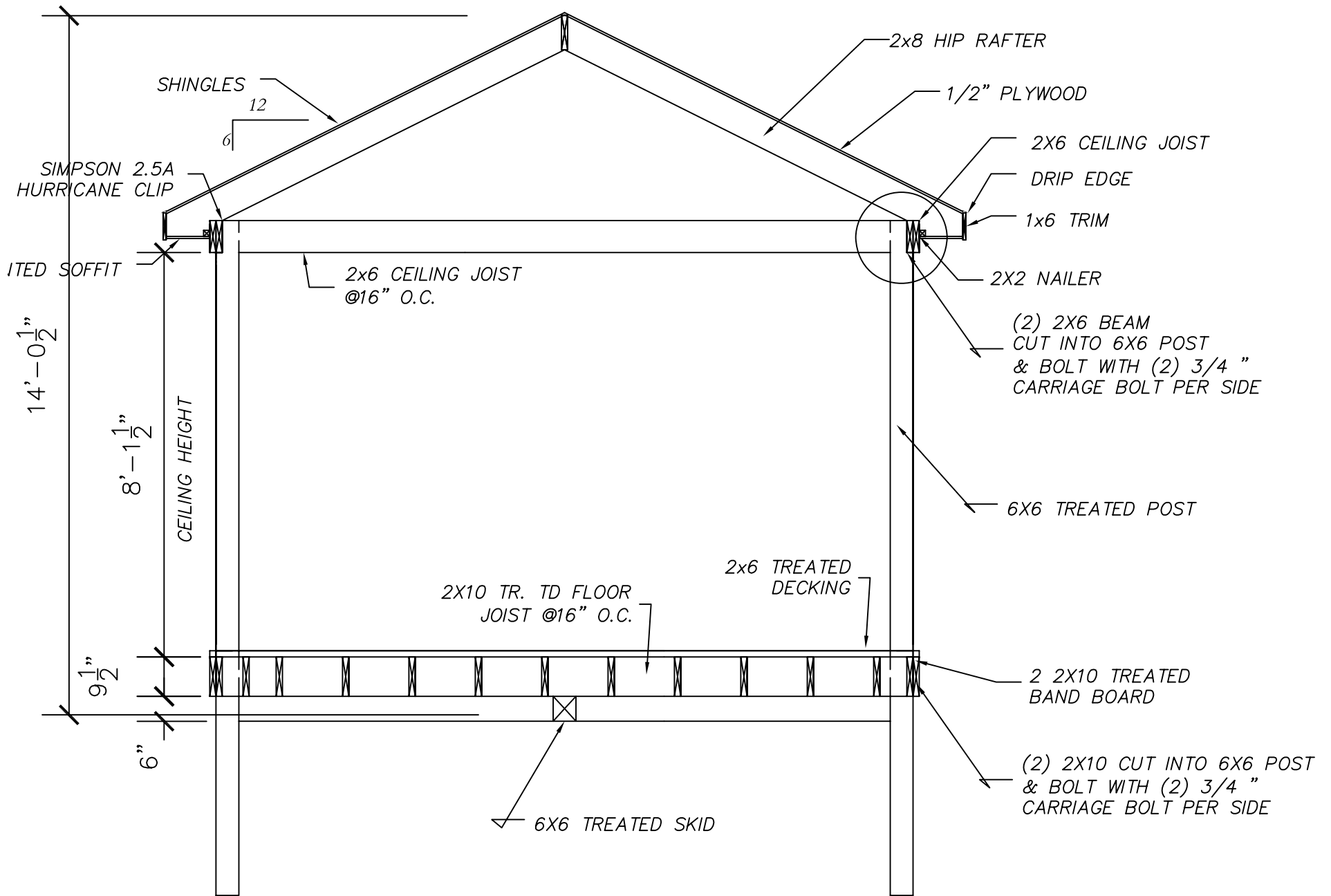

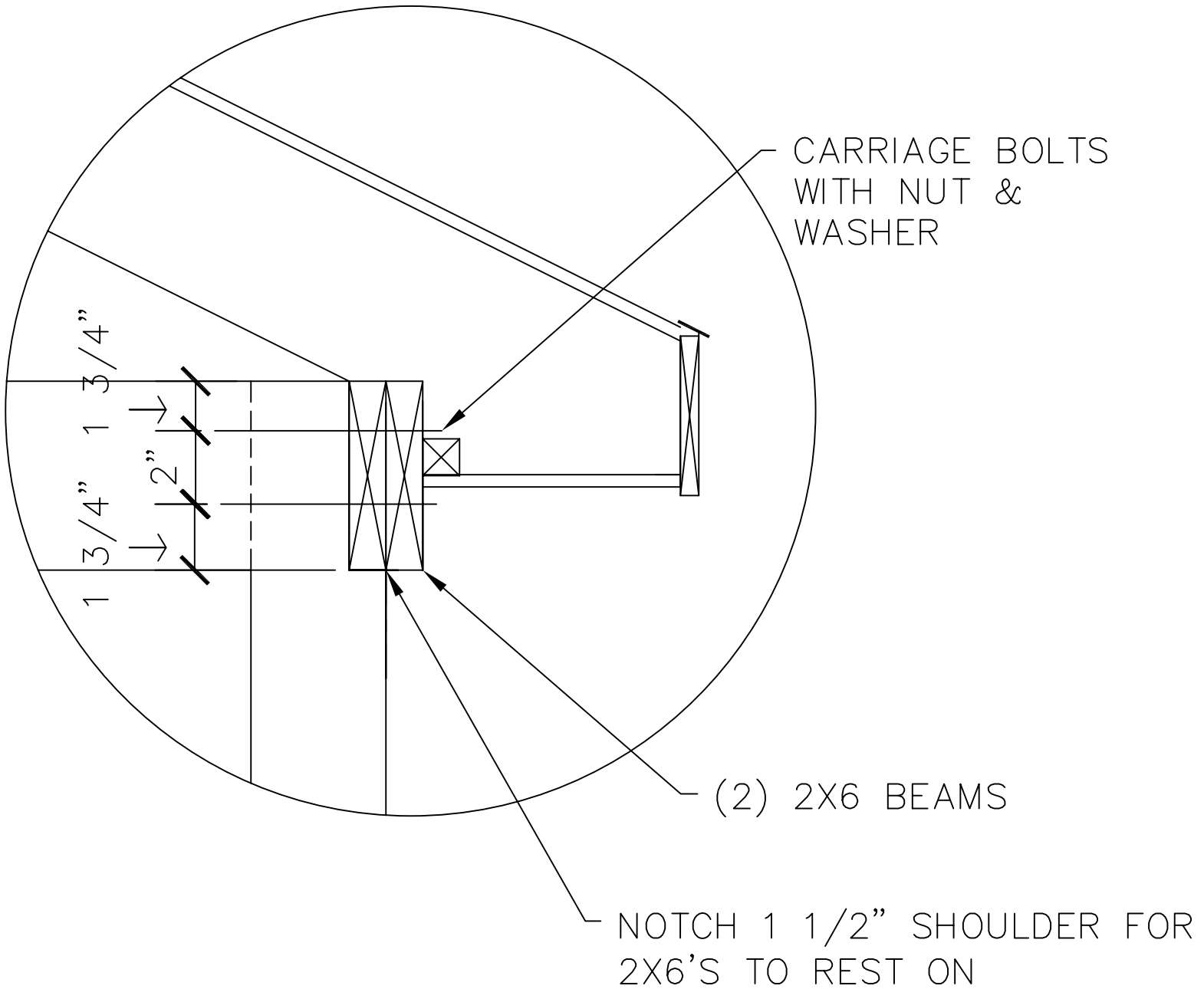

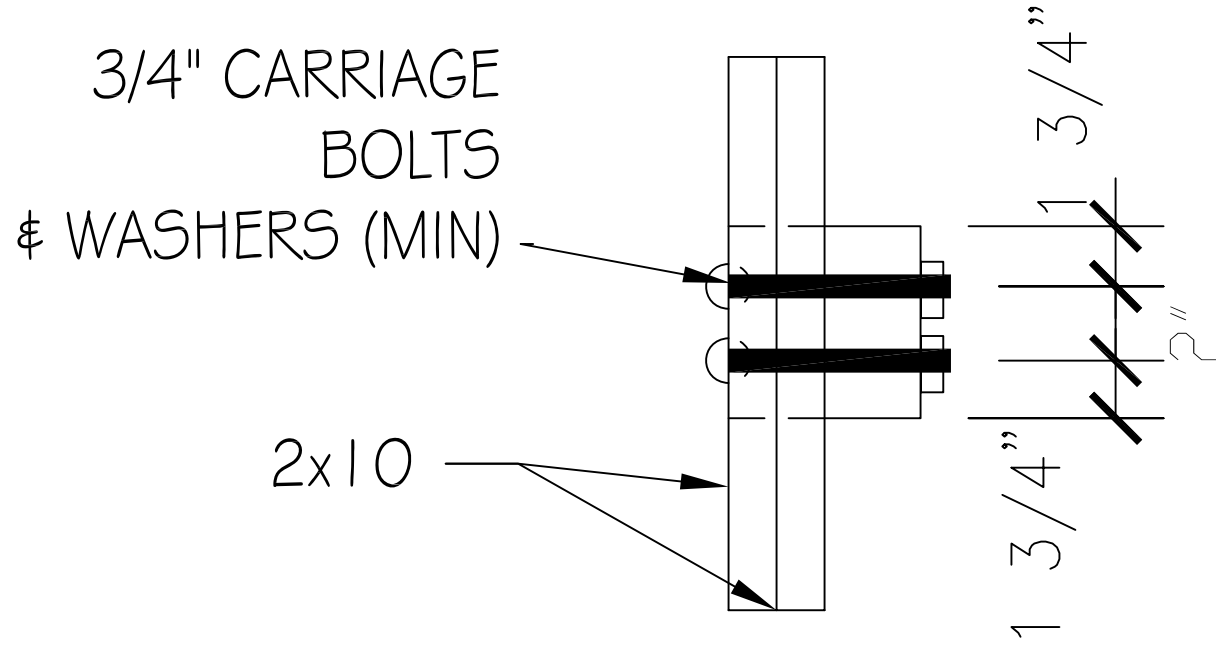

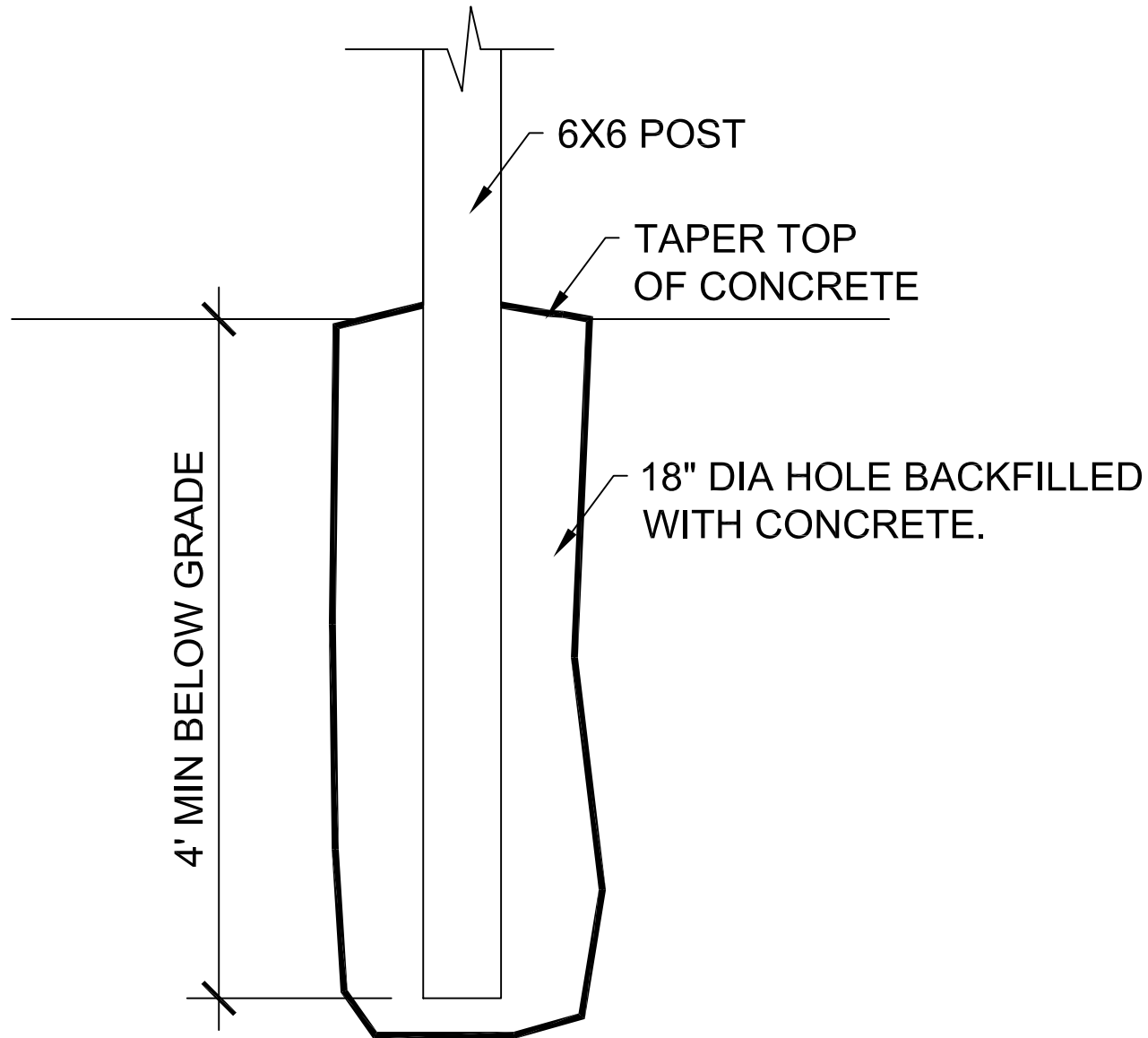

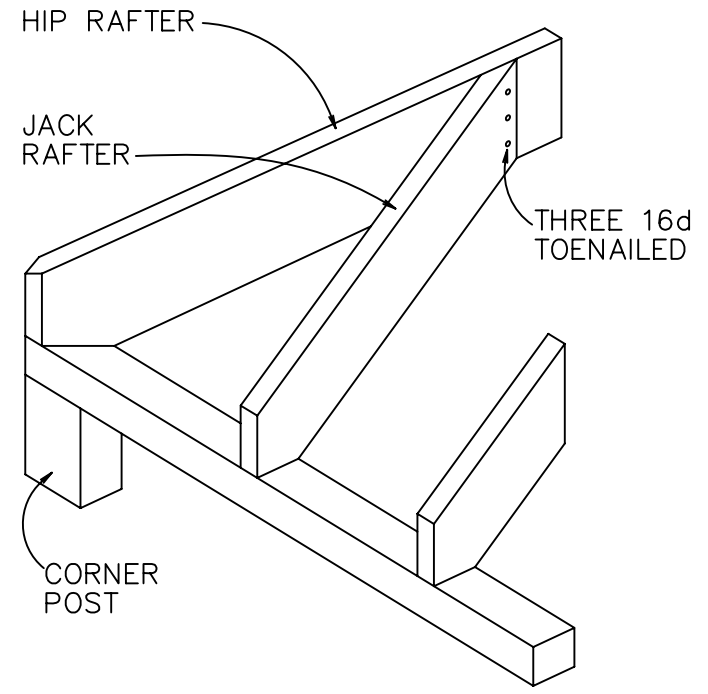
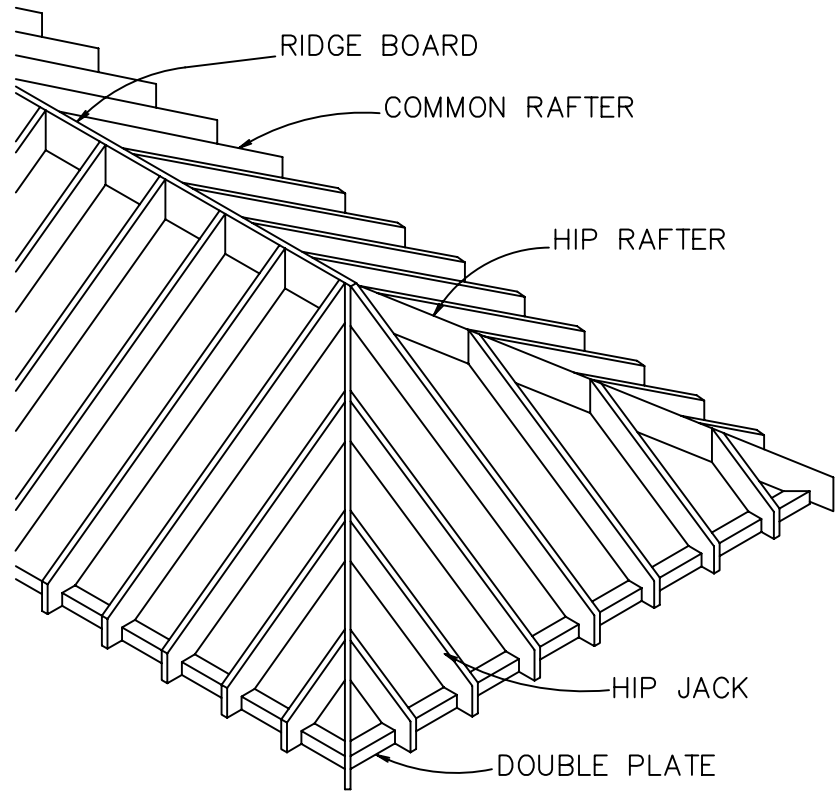

NOTES

1. Exposure 5 in., edge lap 2 in., for all designs.
2. More than one thickness for varying surface texture.
3. Many rated as wind resistant.
4. All rated as wind resistant.

